



Transmet IS

Dewpoint Transmitter

For continuous dew point measurements in hazardous areas, Transmet IS is the ideal transmitter solution with local measurement and certified intrinsically safe design



- CENELEC, FM and CSA Certified
- Easy to install
- High accuracy, repeatability and long-term reliability
- Wide dew point range
- Measurement accuracy up to ± 1 °C dew point
- Fast speed of response
- 0-20 mA and 4-20 mA linear outputs

Complete Dew Point Solution for IS Areas

Transmet IS is an easy to install, self-contained dew-point transmitter for the measurement of the moisture content of flammable and non-flammable gases, and has been specifically designed for use within hazardous areas. Housed in a stainless steel case, Transmet IS offers ingress protection to IP66 (NEMA 4). With a wide operating range from -100 to +20 °C dew point and accuracy of up to 1 °C dew point it is the most complete dew-point transmitter available. Transmet IS has a fast response speed that gives the user a continuous measurement in real time. No configuration or calibration is necessary - Transmet IS is delivered configured and calibrated, ready for installation and operation.

Simplicity

Transmet IS measures the gas under test either by direct insertion into the gas line or by diverting a sample of the gas through its (optional) flow-through stainless steel sample housing. Once the required signal output has been selected using the internally selectable switches and Transmet IS has been connected to the gas sample, power source and monitoring device (through the appropriate safety barriers), it is ready to



use. Of course, for certain applications pre-conditioning of the process gas may be necessary to achieve the correct pressure, or to remove particulate or entrained liquid contaminants. Michell can provide a range of standard or customised sample conditioning systems as a package with Transmet IS.

Reliability is Vital

A dew-point transmitter must operate reliably over its total operating range, in the user's demanding operational environment. Transmet IS has been designed to cope with extreme industrial conditions and is resistant to shock, vibration and extremes of temperature and operating pressure. Furthermore, the advanced design of the Michell Ceramic Moisture Sensor, coupled with extremely competent measurement circuitry, give Transmet IS a class leading accuracy, repeatability and measurement range at pressures up to 30 MPa - in even the most exacting of process conditions, such as natural gas processing or catalytic reformer gas measurement.

Linear Analogue Output

Transmet IS provides a linear analogue output, calibrated in dew point °C, corresponding to the calibrated humidity range from -100 to +20 °C dew point. A simple internal switch allows the user to select either 0-20 mA or 4-20 mA configuration.

Certified Intrinsically Safe

Transmet IS is certified by CENELEC (BASEEFA) to EEx ia IIC T4 when used with a pair of isolation or shunt diode barriers for signal and power supply connections. Transmet IS has been FM listed (USA) CL1, Div1, GpA, B, C & D, T4 and CSA (Canada) certified to Ex 1a (Class 1, Zone 0 and 1). Transmet IS also has accreditation to ATEX directive 94/9/EC. Transmet IS can therefore be safely used in virtually all industrial gas measurement applications.

Output Signal

Transmet IS can be configured by the user to give either a 0-20 mA or 4-20 mA linear signal of the measured dew point (supplied configured for 4-20 mA). This signal can be transmitted to a monitoring device - simple display or process control system - located in a safe area through the appropriate barriers. We can supply the necessary barrier devices or advise you on the correct selection.

Applications

Transmet IS can be applied to almost any air or gas dew-point measurement application situated in a classified hazardous area. Typically Transmet IS will be used for the fiscal metering of natural gas dew point, of the moisture content in catalytic reformer gases, or in the measurement of hydrogen coolant for power plant stators. Transmet IS can of course also be used to measure the dew point of inert gases used in hazardous areas - compressed air systems or inert purge gases used for pipeline and vessel drying and pressure testing.

Display Option

Transmet IS can be connected to, and powered by, Michell's Cermet II Monitor to give local display, alarms and analogue and digital outputs. The Monitor unit must be located in a designated safe area and connected to the Transmet IS by the appropriate System 1 or System 2 safety barriers. See below for more details or ask for our Cermet II brochure.

Technical Specifications

Sensor thread	5/8" UNF parallel
Case	Stainless steel
Ingress protection	IP66 (NEMA 4)
Power	10 to 28 V regulated or unregulated DC supply. Reverse polarity protected
Outputs	Current sink Analogue 0-20 mA or 4-20 mA selectable linear corresponding to °C dew point
Measurement range	-100 to +20 °C dew point -20 to +40 °C temperature
Accuracy	±1 °C from +20 to -60 °C dew point; ±2 °C from -60 to -100 °C dewpoint ±0.3 °C temperature

Resolution	0.1 °C from -80 to +20 °C dew point; 1 °C from -100 to -80 °C dew point; 0.1 °C temperature
Operating temp	-20 to +60 °C
Storage temp	-40 to +70 °C
Operating pressure	From vacuum to 30 MPa
Flow rate	0-10 Nlmin ⁻¹
Gas velocity	20 ms ⁻¹ (max)
Barrier options	System 1: shunt diode barrier (IS earth required) System 2: galvanic isolation barrier (no earth required)
Optional extras	Sensor sampling block, display unit (Michell DI300 Series), power supply module

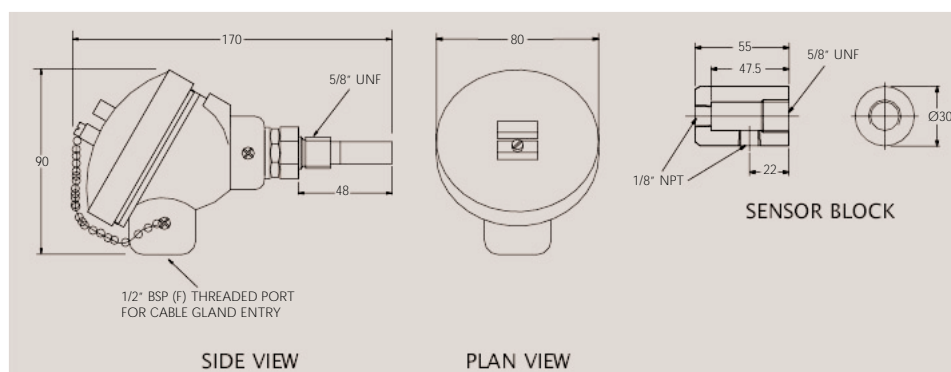

Dimensions mm



0179



Q6284



Michell Instruments Ltd, Nuffield Close, Cambridge CB4 1SS UK
Tel: +44 (0)1223 434800 Fax: +44 (0)1223 434895
e-mail: info@michell.co.uk www.michell-instruments.com

MICHELL
Instruments

